



HiPace™ 300 with TC 110, DN 100 CF-F

**Rugged, powerful turbopump with a pumping speed of up to
260 l/s for N₂**



Pfeiffer Vacuum · Headquarters/Germany

Tel. +49 (0) 6441 802-0 · Fax +49 (0) 6441 802-202 · info@pfeiffer-vacuum.de · www.pfeiffer-vacuum.net

HiPace™ 300 with TC 110, DN 100 CF-F

HiPace™ 300

[Similar Image](#)



- ▶ Rugged, powerful turbopump with a pumping speed of up to 260 l/s for N₂
- ▶ Integrated TC 110 drive electronics, DN 100 CF-F flange
- ▶ Ideal for UHV applications
- ▶ For installation in any orientation
- ▶ Extensive accessories expand the range of applications

Characteristics

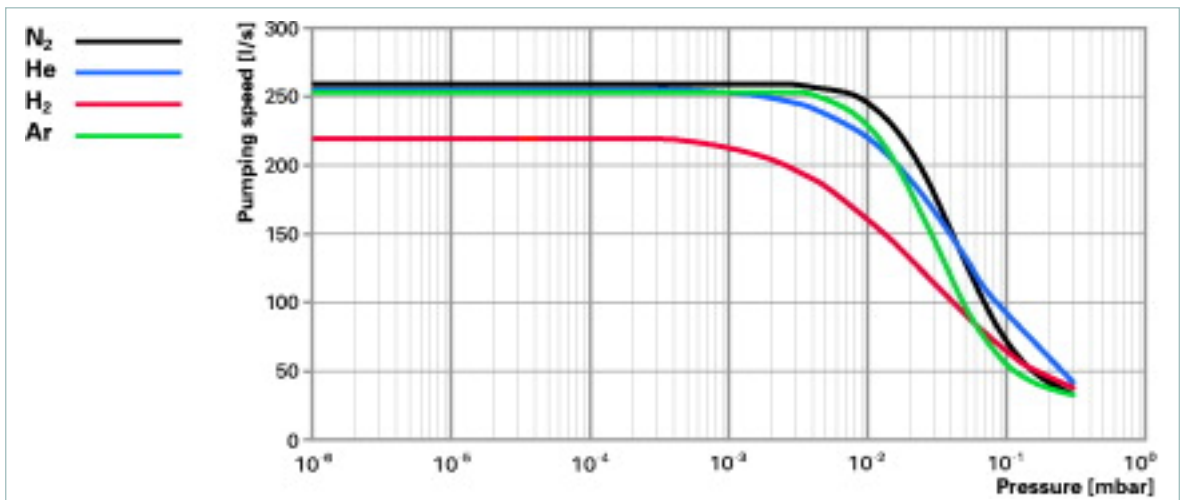

Dimensions

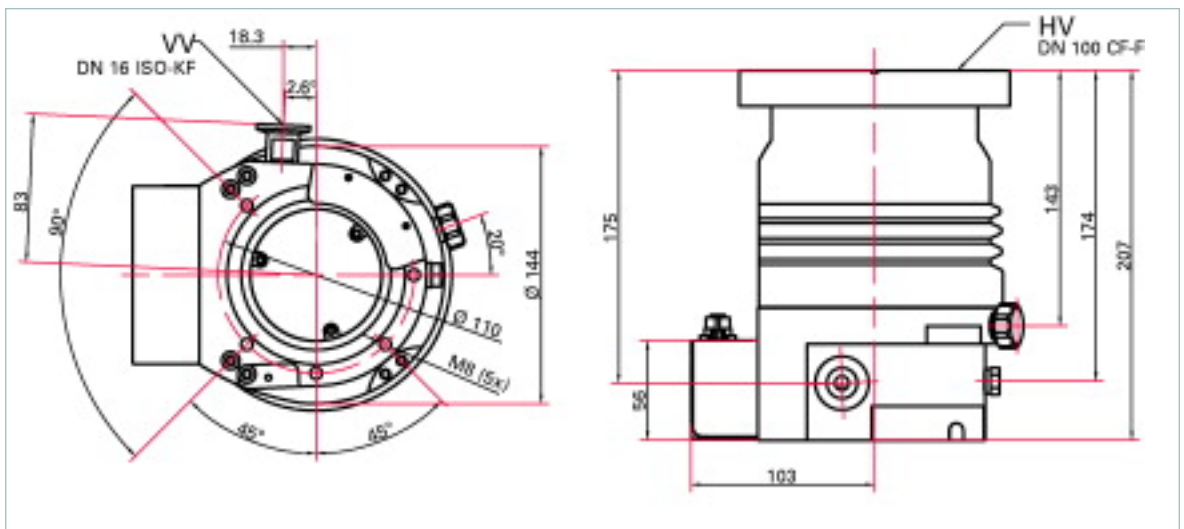

HiPace™ 300 with TC 110, DN 100 CF-F

Technical Data	HiPace™ 300 with TC 110, DN 100 CF-F
Compression ratio for Ar	> 1·10 ¹¹
Compression ratio for CF ₄	> 1·10 ¹¹
Compression ratio for H ₂	9·10 ⁵
Compression ratio for He	> 1·10 ⁸
Compression ratio for N ₂	> 1·10 ¹¹
Cooling method, optional	Water
Cooling method, standard	Air
Cooling water consumption	50 l/h
Cooling water temperature	15-35 °C
Flange (in)	DN 100 CF-F
Flange (out)	DN 16 ISO-KF
Fore Vacuum max. for N ₂	15 mbar
Gas throughput at full rotational speed for Ar	2 mbar l/s
Gas throughput at full rotational speed for CF ₄	2 mbar l/s
Gas throughput at full rotational speed for H ₂	> 14 mbar l/s
Gas throughput at full rotational speed for He	8 mbar l/s
Gas throughput at full rotational speed for N ₂	5 mbar l/s
Interfaces	RS-485, Remote
Permissible magnetic field max.	5.5 mT
Protection category	IP 54
Pumping speed for Ar	255 l/s
Pumping speed for CF ₄	200 l/s
Pumping speed for H ₂	220 l/s
Pumping speed for He	255 l/s
Pumping speed for N ₂	260 l/s
Rotation speed ±2%	60000 rpm
Run-up time	3.5 min
Sound pressure level	50 dB (A)
Ultimate pressure with OnTool™ DryPump	< 5·10 ⁻¹⁰ mbar
Venting connection	G 1/8"
Weight	8.2 kg
Order number	PMP03991

HiPace™ 300 with TC 110, DN 100 CF-F

Accessories	HiPace™ 300 with TC 110, DN 100 CF-F
	PM016636-T
	PM016655-T
115 V AC mains cable with UL plug, IEC power socket (straight), 3 m	P4564309ZE
208 V AC mains cable with UL plug, 3 m	P4564309ZF
230 V AC mains cable with Euro-style safety plug, IEC power socket (straight), 3 m	P4564309ZA
24 V DC venting valve, G 1/8", for connection to TC 110	PMZ01290
Accessories package for HPU - Power supply, software and PC cable	PM061005-T
Air cooling for HiPace 300 with TC 110, plug M8	PMZ01301
Air cooling for HiPace 80 with TC 110, plug M8	PMZ01300
Angled screw coupling for venting valve	PM143877-T
Backing pump relay box, single phase 20 A, for TC 110/TCP 350	PM061373-T
Backing pump relay box, single phase 5 A, for TC 110/TCP 350	PM061372-T
Connection cable, plug M12, RJ 45	PM051726-T
Connection cable, TC 110 - TPS/DCU 110/180 with 2 accessory ports and second D-Sub	PM061755-X
Connection cable, TC 110 - TPS 110/180 with accessory ports and bridges	PM061552-T
Connection cable for HiPace with TC 110	PM061543-T
Connection cable for HiPace with TC 110	PM061892
Connection cable for linking HiPace with TC 110 to power supply TPS/DCU 110/111/180/181	PM061350-T
Connection cable for linking HiPace with TC 110 to power supply TPS/DCU 110 / 111 / 180 / 181	PM061351-T
Control cable 3/2 pole, TC 100 - MVP, 0,5 m	PM061433-x
DCU 002, Display control unit	PM061348-T
DCU 180, Display control unit incl. power supply	PMC01821
Extension cable M8 on M8	PM061783-T
Front panel kit for TPS 181	PM061394-T
Heating jacket for HiPace 300 with TC 110/TCP 350, 115 V AC, UL plug	PM061365-T
Heating jacket for HiPace 300 with TC 110/TCP 350, 208 V AC, UL plug	PM061364-T
Heating jacket for HiPace 300 with TC 110/TCP 350, 230 V AC, Euro-style safety plug	PM061363-T
Housing for plug, water resistant, 15-pole, D-Sub, IP 54	P0998016
HPU 001, handheld programming unit	PM051510-T
Interface cable, 3 m, M 12	PM061283-T
Interface cable RS-485, 3 m, M12, straight, 90°	PM061791-T
Power supply plug TC 110 or plug for interface E74, angled	P4723111
Power supply plug TC 110 or plug for interface E74, straight	P4723110
Power supply plug TPS 110/180/310/400 DC out	P4723102
Protection screen for Turbopumps, DN 100 CF-F	PM016336
Remote plug, water resistant, 26-pole, HD, IP 54	PM061880-T

HiPace™ 300 with TC 110, DN 100 CF-F

Accessories	HiPace™ 300 with TC 110, DN 100 CF-F
Sealing gas throttle for HiPace 300,400 and 700	PMZ01317
Sealing gas valve for HiPace 300 with TC 110	PMZ01311
Set of hexagon bolts, 16 count, M8, DN 100 CF	PM016690-T
Set of stud screws, 16 count, M8, DN 100 CF	PM016692-T
Splinter shield for Turbopumps, DN 100 CF-F flange	PM016315
TC 110 - TPS/DCU 110/180 with 3 accessory ports, RS-485	PM061512-T
TCS 11, adapter for TC 110 with interface RS-485	PM061636-U
TCS 12, adapter for TC 110 with interface RS-485 and 4 accessory ports	PM061638-U
TCS 13, adapter for TC 110 with interface RS-485 and 2 accessory ports	PM061856-U
Tele TC cable 110	PM061773-T
TPS 180, mains pack for wall/standard rail fitting	PM061341-T
TPS 181, mains pack 19" rack module 3 RU	PM061345-T
TTV 001, air drier for venting turbopumps	PMZ00121
TVV 001 fore-vacuum safety valve, 115 V AC	PMZ01206
TVV 001 fore-vacuum safety valve, 230 V AC	PMZ01205
USB converter to RS-485 interface	PM061207-T
Venting flange DN 10 KF-G1/8"	PM033737-T
Vibration damper for HiPace 300 and HiPace 400, DN 100 CF-F	PM006488-X
Wall rail fitting TPS 110/180/310/400	PM061392-T
Water cooling for HiPace 300, TC 110	PM016624-T
Y-Connector M12 to RS-485	P4723010